

Honeywell

C8600A CO Alarm

OWNER'S GUIDE

RESIDENTIAL USE ONLY

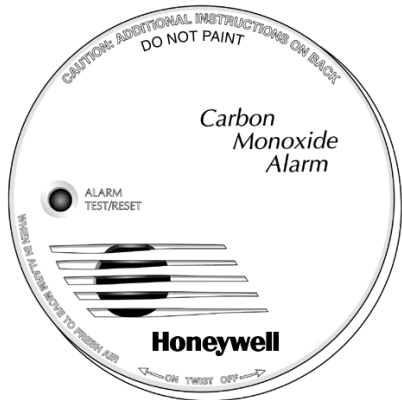

69-1513-1

Features

- **Patented carbon monoxide (CO) alarm technology detects CO similar to human body's response.**
- **Detects and warns against conditions that can lead to acute and chronic effects of CO poisoning.**
- **Detects toxic CO gas resulting from incomplete combustion such as emitted from appliances, furnaces, fireplaces and auto exhaust.**
- **Detects CO gas from any source of combustion.**
- **Use in combination with other combustible gas, fire or smoke alarms.**
- **Detects levels of carbon monoxide at 70 ppm and above.**
- **For residential use only.**

What You Should Know About Carbon Monoxide (CO)

- Colorless, odorless, and tasteless gas.
- Cumulative poison.
- Even low levels can cause brain and other vital organ damage in unborn infants with no effect on the mother.
- Symptoms of carbon monoxide poisoning should be discussed with all members of the household:
 - a. Mild Exposure—Slight headache, nausea, vomiting, fatigue (often described as flu-like symptoms).
 - b. Medium Exposure—Severe throbbing headache, drowsiness, confusion, fast heart rate.
 - c. Extreme Exposure—Unconsciousness, convulsions, cardio-respiratory failure, death.

- d. Disoriented—Victims are often aware they are not well, but are so disoriented, they are unable to save themselves by either exiting the home or calling for assistance. (Young children and household pets may be the first affected.)

What CO Alarm Can/Cannot Do

- This alarm indicates the presence of carbon monoxide gas at the sensor. Carbon monoxide gas may be present in other areas.
- This alarm is not a substitute for other combustible gas, fire or smoke alarms.
- This CO alarm may not sense CO on a different level or floor of a residence or building; for example, a second floor alarm may not sense a CO leak on the first floor or in the basement:

- Place alarms on every level of a residence as shown in Fig. 1.
- This CO alarm may not be heard behind closed or partly closed doors such as in bedrooms:
- Place alarms in each bedroom and in the hallway if bedroom doors are closed or partly open at night; an alarm outside a door may not awaken occupants.



WARNING

CO Alarm does not measure in compliance with Occupational Safety and Health Association (OSHA) commercial or industrial standards. CO Alarm is for use only in indoor family living units.

This alarm has not been investigated for CO detection below 70 ppm.

WARNING

**Individuals with Medical Problems
Alert.**

**Inability of this device to detect low
carbon monoxide levels below 70
ppm.**

Use alternate detection and warning
device that provides audible and visual
signals for CO levels below 30 ppm.

- CO alarms are not a substitute for insurance. Installing CO alarms may qualify you for lower insurance rates.
 - This CO alarm is not designed for use in marine or recreational vehicles.

Developing Your CO Safety Plan

WARNING

Actuation of your CO Alarm indicates the presence of carbon monoxide that can KILL YOU.

If alarm sounds:

- 1) Operate reset/silence button.
- 2) Call your emergency services telephone number (-----), fire department or 911.
- 3) Immediately move to fresh air outdoors or near an open door/window. Take a head count to check that all persons are accounted for. Do not re-enter your home or move away from the open door/window until the emergency services responders have arrived, the

home is aired out, and your alarm remains in normal condition.

- 4) After following steps 1-3, if your alarm reactivates within a 24-hour period, repeat steps 1-3 and call a qualified appliance technician (-----) to investigate sources of CO from fuel-burning equipment and appliances, and inspect this equipment for correct operation. If problems are identified during this inspection, have the equipment serviced immediately. Note any combustion equipment that the technician did not inspect, and consult the manufacturer's instructions, or contact the manufacturers directly for more information about CO safety and this equipment. Make sure motor vehicles are not, and have not been operating in an attached garage or garage adjacent to the home.

- This CO alarm can quickly alert you to the presence of CO levels equal to or greater than 70 ppm.
- This alarm cannot prevent toxic CO emissions. (Regular maintenance of combustion appliances and their vent systems is advised.)
- This alarm cannot protect you from hazards such as gas leaks or explosions. The ultimate protection against toxic CO gas is your responsibility.
- This alarm is designed to detect carbon monoxide entering its sensing chamber. It does not sense combustible gas such as natural gas, propane or butane, heat, smoke, or flames.

To protect yourself and your family from toxic CO poisoning, create an effective, comprehensive safety program:

1. Install CO detectors correctly, using the instructions in this Owner's Guide
2. Replace batteries every year (or sooner if intermittent chirp sound is heard, indicating a low battery condition).
3. Develop a family escape plan and practice it with your entire family, especially small children.
 - a. Draw a floor plan of your home and find two ways to exit each room; and an additional way to exit a bedroom without opening the door.
 - b. Teach your children what the CO alarm signal means and how to exit your home by themselves, if necessary.

- c. Decide on a meeting place that is a safe distance from your house and make sure all children understand where they should go to wait if there is a dangerous CO condition.
- d. Conduct CO safety drills at least every six months to be sure everyone, especially small children, know what to do to escape safely.
- e. Know where to go to call the Fire Department from outside the home.

Installing Residential CO Alarm

NOTICE

The manufacturer strongly recommends replacement of alarm six years after date of purchase. Under no circumstances should the alarm be used seven years after date of purchase.

Selecting a Location

The CO alarm is designed for use only within a single-residential living unit. It can be used in a multi-family building, but should not be placed outside of residential units, such as on outside porches, in corridors, lobbies, basements, or in other apartments.

Early warning of developing poisonous CO conditions is critical. It is very important to carefully select the location for the alarms. The National Fire Protection Association (NFPA) statistics show that most fatal occurrences happen at night while people are sleeping.

Recommended Mounting Locations

- Place a CO alarm inside each bedroom if the occupant closes the door while sleeping.
- See Fig. 1 for single-floor residence CO alarm locations.

- See Fig. 2 for multi-level residence CO alarm locations.
- Mount the CO alarm on the wall or ceiling.
- Locate the top of the alarm at least 3 ft (.9 meter) from the floor. See Fig. 3.
- Mount the alarm as close as possible to the center of a hallway or room.
- Mount the edge of the alarm at least four inches from any adjoining wall.

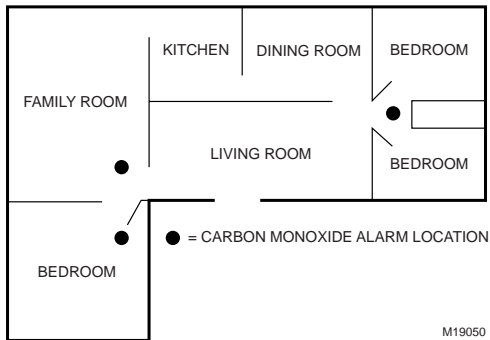

Fig. 1. Single-floor residence CO alarm locations.

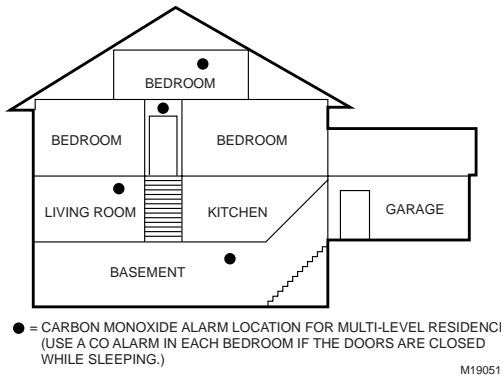

Fig. 2. Multi-level residence CO alarm locations.

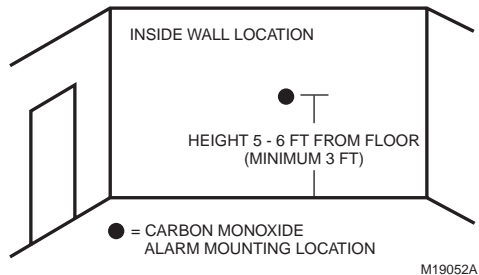

Fig. 3. CO alarm wall mounting location.

LOCATIONS TO AVOID

- Near an open window or door with fresh air entering the opening and delaying the CO from reaching the alarm.
- In damp or very humid areas or next to bathrooms with showers; install detectors at least 10 ft (3 meters) away from bathrooms.
- In very cold or very hot environments or in unheated buildings or outdoor rooms where the temperature can drop below or rise above the operating range of the alarm; temperature limits for correct operation are 40° to 100°F (5° to 38°C).
- In areas where nuisance alarms can result because CO alarms are placed where they cannot operate correctly such as:
 - Within 5 ft (1.5M) of any cooking appliance or furnace.

- In areas of limited ventilation where household cleaning supplies or similar contaminants are used.

CONDITIONS THAT CAN RESULT IN TEMPORARY CO SITUATION

- Excessive spillage or reverse-venting of fuel-burning appliances from outdoor ambient conditions such as:
 - Wind direction and/or velocity, including high gusts of wind; heavy air in vent pipes (cold /humid air with extended periods between cycles).
 - Negative pressure differential resulting from using exhaust fans.
 - Simultaneous operation of several fuel-burning appliances that compete for limited internal air.

- Vent pipe connections vibrating loose from clothes dryers, furnaces, or water heaters.
- Vent pipe obstructions or unconventional vent pipe designs .
- Extended operation of unvented fuel-burning devices (range, oven, or fireplace).
- Temperature inversions that can trap exhaust gases near the ground.
- Car idling in an open or closed area of the garage or near the home.

Mounting Your CO Alarm

NOTICE

Device is sealed; cover is not removable.

1. Select mounting location (see Recommended Mounting Locations section).
2. Remove the mounting plate from the back of the alarm by holding the back of the mounting plate and twisting the alarm in the direction of the Off arrow on the alarm front cover.

NOTE: Be sure the UP wall mounting text and arrow are pointing up.

3. Align the mounting plate on the wall, with the UP arrow pointing up.
4. Attach the mounting plate to the surface, using the screws and anchors provided to secure the mounting plate. See Fig. 4.

NOTE: The battery is installed reversed for shipping. It requires removal and re-installing in the correct orientation.

5. Remove and reinstall the battery in the correct (+/-) orientation as shown on the inside of the battery door. (After installing the battery, close the battery door securely.) See Fig. 5.

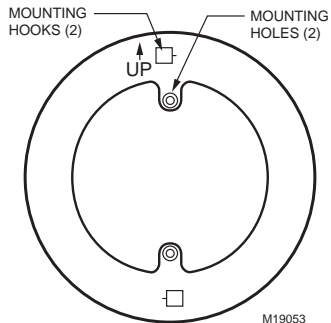

Fig. 4. Installing mounting plate.

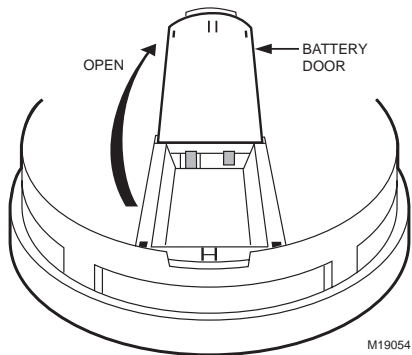

Fig. 5. Installing battery.

NOTICE

If no battery is installed, the battery door will not close and the unit cannot be attached to the mounting bracket.

6. Listen for the alarm to beep once to indicate correct battery installation.
7. Holding the alarm with the front facing you; place the mounting holes of the alarm over the mounting hooks of the mounting plate.
8. Turn the alarm in the direction of the On arrow on the alarm cover until it locks in place. See Fig. 6.

NOTE: A tamper-resistant locking pin is provided in the bag with the screws and anchors. Use this pin to deter children and others from removing the alarm from the mounting plate.

9. To use the tamper-resistant locking pin, insert it into the hole in the side of the alarm after the device is installed on the mounting plate; see Fig. 7.

NOTE: To change the battery, remove the tamper-resistant pin using a long-nosed pliers.

10. Use a long-nosed pliers to pull out the tamper-resistant locking pin to allow removing the device from the mounting plate to replace the battery.
11. Locate the two self-adhesive labels in the packing box. Write the telephone number of the emergency service provider and a qualified technician in the spaces provided on the labels.

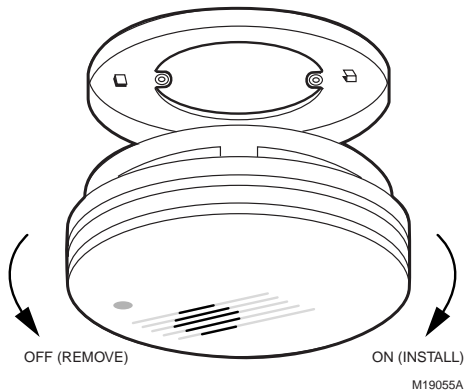

Fig. 6. Installing alarm on mounting plate.

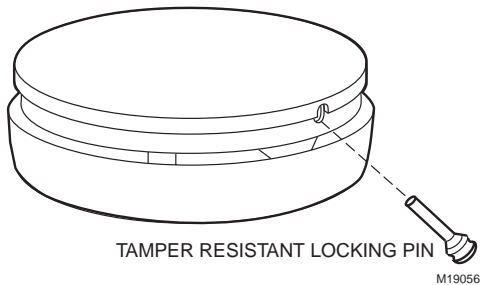

Fig. 7. Inserting tamper-resistant locking pin.

12. Place one label next to the alarm and the other label near a source of fresh air where you plan to gather after the alarm indicates the presence of carbon monoxide.

Weekly Alarm Testing

Test the alarm each week to ensure the alarm is operating correctly:

1. Push the test button until a short beep is heard (within three seconds).
2. Release the test button.
3. Wait and observe during alarm test:
 - a. Red LED light flashes four to six times.
 - b. Alarm sounds two patterns after test.
 - c. Alarm resumes normal operation.

Troubleshooting

See Table 1 for meaning of alarm LED and beeping signals.

Table 1. Troubleshooting Alarm Signals and Repeating Sound Patterns.

Red LED/Beeping Action	Meaning
Flashes once every 30 seconds.	Normal operation; alarm is powered.
Turns on for 2 seconds and off for 3 seconds with 4 short beeps for 1 second and 5 seconds of silence.	Alarm condition; alarm is sounding.
Double flashes and beeps once every 30 seconds.	Trouble condition.
Beeps (chirping sound) once every 30 seconds for 7days minimum.	Low battery; battery needs replacing.
Reset (silence) after alarm sounding when push and hold test button for 3 seconds to silence alarm for 4 minutes.	Silence after alarm condition; detector sounds again after 4 minutes until unsafe CO concentration is reduced.

Maintenance

Cleaning Your Alarm



CAUTION

Cleaning Chemical Hazard.

Can damage CO alarm.

Avoid using household cleaning agents, paints, varnishes, or other chemicals.

Use only a vacuum cleaner or soft cloth.

NOTE: Keep your CO Alarm clean but do not wash it with water or other household cleaning agents.

To clean your device:

1. Remove it from the mounting bracket.
2. Use your vacuum cleaner hose to clean the inside of your alarm; vacuum through the openings around the alarm perimeter.
3. Wipe the outside with a cloth.

After cleaning your device:

1. Reinstall your alarm and test it using the test button. (Testing your alarm each week is recommended.)
2. Test your alarm each week and repair or replace it, as needed.

Replacing Your Battery

NOTE: When using the tamper-resistant locking pin, be sure to remove it before replacing your battery.

1. Use a long-nosed pliers to pull out the tamper-resistant locking pin to allow removing the device from the mounting plate to replace the battery.
2. Remove the alarm from the mounting plate by turning the alarm in the direction of the Off arrow on the cover.
 - Use the battery recommended. (A fresh battery should last for one year under normal operating conditions.)
3. Verify that you have a 9-volt alkaline battery and install it; see Fig. 5 (Duracell® MN1604 is recommended).

WARNING

Replacement Battery Hazard.

Use only battery specified.

Using different battery than 9-volt Duracell® MN1604 can have detrimental effect on CO alarm operation and performance.

NOTE: Constant exposures to high or low temperatures or to high humidity can reduce battery life.

Limited Five-Year Warranty

Honeywell warrants this product, excluding battery, to be free from defects in the workmanship or materials, under normal use and service, for a period of five (5) years from the date of purchase by the consumer. If, at any time during the warranty period, the product is defective or malfunctions, Honeywell shall repair or replace it (at Honeywell's option) within a reasonable period of time.

If the product is defective,

- (i) return it, with a bill of sale or other dated proof of purchase, to the retailer from which you purchased it, or
- (ii) package it carefully, along with proof of purchase (including date of purchase) and a short description of the malfunction, and mail it, postage prepaid, to the following address:

Honeywell Return Goods
Dock 4 MN10-3860
1885 Douglas Dr N
Golden Valley, MN 55422

This warranty does not cover removal or reinstallation costs. This warranty shall not apply if it is shown by Honeywell that the defect or malfunction was caused by damage that occurred while the product was in the possession of a consumer.

Honeywell's sole responsibility shall be to repair or replace the product within the terms stated above. HONEYWELL SHALL NOT BE LIABLE FOR ANY LOSS OR DAMAGE OF ANY KIND, INCLUDING ANY INCIDENTAL OR CONSEQUENTIAL DAMAGES RESULTING, DIRECTLY OR INDIRECTLY, FROM ANY BREACH OF ANY WARRANTY, EXPRESS OR IMPLIED, OR ANY OTHER FAILURE OF THIS PRODUCT. Some states do not allow the exclusion or limitation of incidental or consequential damages, so this limitation may not apply to you.

THIS WARRANTY IS THE ONLY EXPRESS WARRANTY HONEYWELL MAKES ON THIS PRODUCT. THE DURATION OF ANY IMPLIED WARRANTIES, INCLUDING THE WARRANTIES OF MERCHANTABILITY AND FITNESS FOR A PARTICULAR PURPOSE, IS HEREBY LIMITED TO THE ONE YEAR DURATION OF THIS WARRANTY. Some states do not allow limitations on how long an implied warranty lasts, so the above limitation may not apply to you.

This warranty gives you specific legal rights, and you may have other rights which vary from state to state. If you have any questions concerning this warranty, please write Honeywell Customer Care, 1985 Douglas Dr N, MN101461, Golden Valley, MN 55422 or call 1-800-468-1502.

Honeywell

Automation and Control Solutions

Honeywell

1985 Douglas Drive North

Golden Valley, MN 55422

69-1513-1 G.H. Rev 11-02



Printed in U.S.A. on recycled paper containing at least 10% post-consumer paper fibers.

www.honeywell.com/yourhome